



# SUPERFLEX PREDUSTER ■ BREADER



For Drum Style or Flat-Bed Coating in One Machine



**NEW**

Get That Hand Tossed  
Homestyle Look without  
a Drum!  
Less Breading Loss,  
Less Dust.



Auto Hopper



CE  
USDA  
CA

The Superflex Runs it All...  
J Crumb ■ Flour ■ ABC

- Accepts battered product
- Compact design saves valuable line space
- Opens for easy cleaning
- Closes for dust control
- No augers
- Automatic spreading

# NOTHUM

FOOD PROCESSING SYSTEMS

# COATING SOLUTIONS



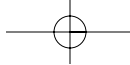

# NOTHUM

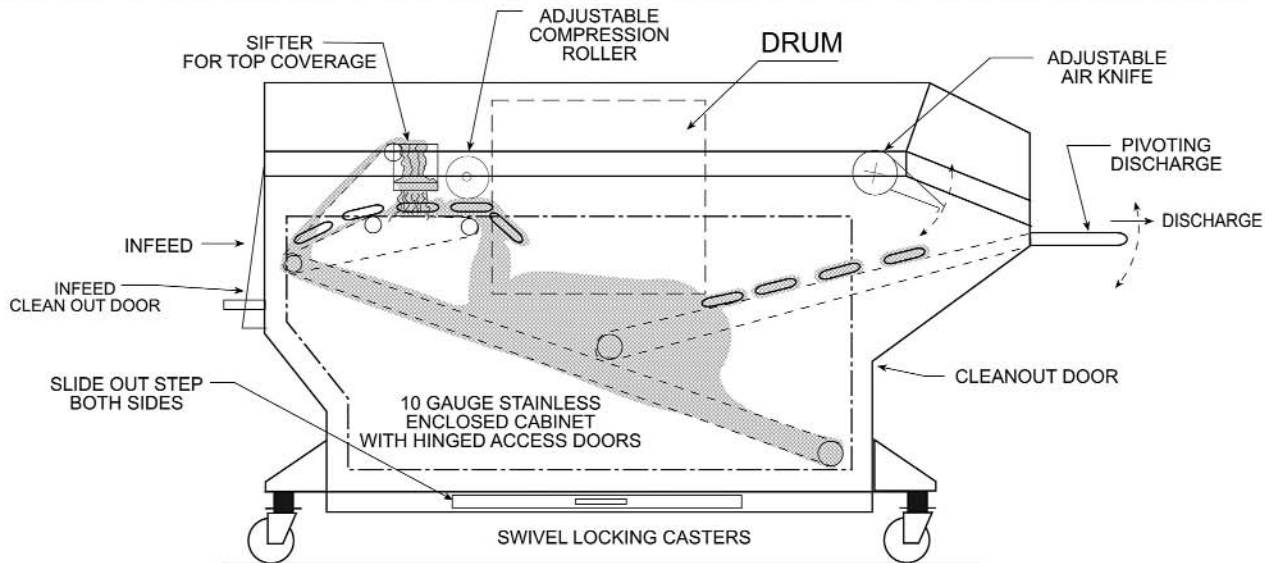

## Superflex

### General Specifications

	SF 14	SF 24	SF 40
Length O/A	108"	108"	108"
Width O/A	43"	53"	67"
Height O/A	60"	60"	60"
Infeed Height	36" +/- 2 1/2	36" +/- 2 1/2	36" +/- 2 1/2
Discharge Height	36" +/- 2 1/2	36" +/- 2 1/2	36" +/- 2 1/2
Pivoting Discharge Nosebar	6"	6"	6"
Actual Belt Width	16"	26"	40"

SF 14, SF 24 and SF 40

240V 3ph 20amp / 480V 3ph 10amp

Electrically driven

20gpm at 800psi

Hydraulically driven

\*Specifications are approximate and subject to change

**Includes:** Flat-bed preduster/breeder, Stainless steel uni-frame construction, Flat flex wire belt, Adjustable bullet-nose discharge, Stainless steel compression roller, Air knife and blower, Swivel locking casters, Electric or hydraulic motors, Touch screen and PLC, Dust covers, Automatic add hopper and breading level sensor, *Runs flour and crumb coatings*

**Options:** 200 pound bulk feed hopper and other texturizing devices

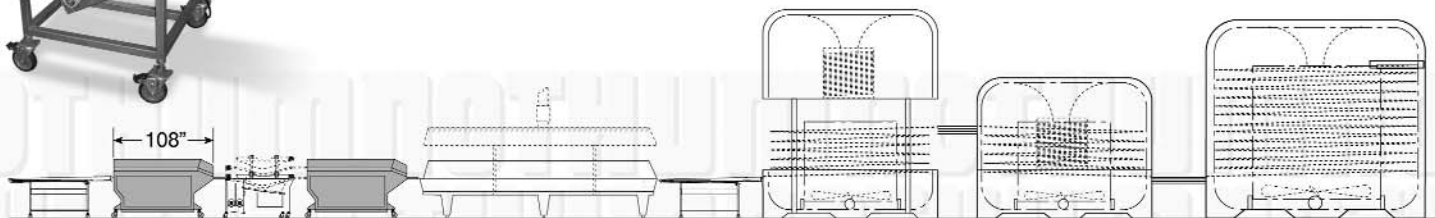

Nothum's equipment, processes and concepts may be covered by one or more of the following US patents.

Other domestic and international patents pending.

5937744, 6158322, 6305274, 6510810, 6976369, 7107899

631 South Kansas, Springfield, MO 65802 USA

nothum@nothum.com

Phone 1-417-831-2816 Toll Free 1-800-435-1297 Fax 1-417-866-4781

www.nothum.com

